



Selecting and Installing Steadi-Flex® compensating cable SPECIAL CONSIDERATIONS

Steady-Flex cable is a wide-loop version of our standard Whisper-Flex compensating cable. Because of its wider natural loop, Steady-Flex cable can be positioned closer to the car's centerline. This improves car balance and ride quality for installations with side counterweights and long hang lengths.

ATTACHMENT POINTS/ CALCULATING LOOP DIAMETER

Set the distance between the counterweight and car hitch points to close proximity of the dynamic loop widths listed in the table below. NOTE: During the selection process, give special consideration to the dynamic (in motion) loop width. Steady-Flex is NOT a one-for-one replacement for Whisper-Flex. Pit dimension and possible obstructions should be considered when specifying Steady-Flex.

STEADI-FLEX SIZES AND DYNAMIC LOOP WIDTHS		
Part Number	Product Code	Dynamic loop width inches • meters
18-L15-97	SFC 15	46 • 1.17
18-L20-97	SFC 20	47 • 1.20
18-L25-97	SFC 25	48 • 1.22
18-L30-97	SFC 30	49 • 1.25
18-L35-97	SFC 35	50 • 1.27
18-L40-97	SFC 40	50 • 1.27

Loop widths will be up to 10" • 254 mm smaller when car is stationary

SELECTION OF SUPPORT HARDWARE

Support brackets, U-bolts, S-hooks and heavy duty couplings specifically designed for Steady-Flex cable must be used to ensure safe installations. See Figure 1 for a typical installation. Use the installation kits listed below with Steady-Flex cables:

STEADI-FLEX INSTALLATION KITS	
Part Number	For Use on These Cables
JCC-20-CHN	SFC 15 and 20
JCC-30-CHN	SFC 25 and 30
JCC-40-CHN	SFC 35 and 40

SELECTION AND PLACEMENT OF DAMPING DEVICES

The WF-RDD4 Super Swayless damping device (shown in Figure 2 installed on a floor-mounted bracket SSL-FMB-48) is designed for use with Whisper-Flex and Steady-Flex compensating cables. Use two devices to maintain smooth compensating cable operation for car speeds of up to 700 feet/min • 3.56 m/sec.

We recommend using the WF-RDD4 (shown right) with free-turning polyurethane rollers to contain and dampen any oscillation or cable sway that may be generated by cable motion at higher speeds.

Position the damping devices directly below the car and counterweight hitch points in accordance with the appropriate dynamic spacing.

Figure 1

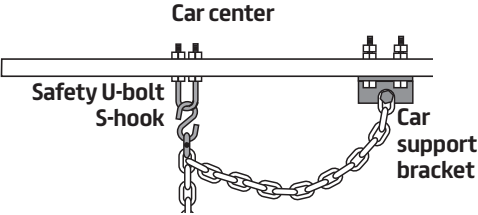
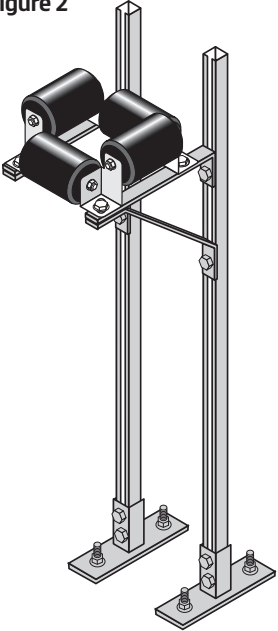

Figure 2



Draka EHC

A Brand of Prysmian Group

Draka EHC
2151 N. Church Street | Rocky Mount, NC 27804
+1-877-DRAKA EP (877-372-5237)
www.DrakaEHC.com | www.prysmiangroup.com

Selecting and Installing Steadi-Flex[®] compensating cable (con't)



Mount them three feet from the base of the loop to insure the cable travels vertically as it passes through the rollers (Figure 3). Mounting brackets can be seen in the Wire Rope and Compensation section of the Draka catalog.

When the car is stationary, the cable will drape on the inside rollers as shown in Figure 4. As the car accelerates, the loop will expand to match the dimension listed in Table 1.

SHALLOW PIT CONSIDERATIONS

The damping devices must be mounted above the cable's loop curvature so that the cable is vertical as it passes through the rollers.

At a minimum, the damping device must be mounted above the pit floor by a distance equal to a floor clearance of 6 inches plus one half of the dynamic loop width.

If the compressed buffer height on an installation does not allow adequate space to follow these criteria, the ShallowSwayless damping device (WFDD-50L) should be specified.

A follow-up inspection (1 - 2 weeks after installation) is recommended to ensure proper placement of the damping devices. Adjustments should be made as needed to minimize contact between the cable and rollers while the elevator is in operation.

Figure 3

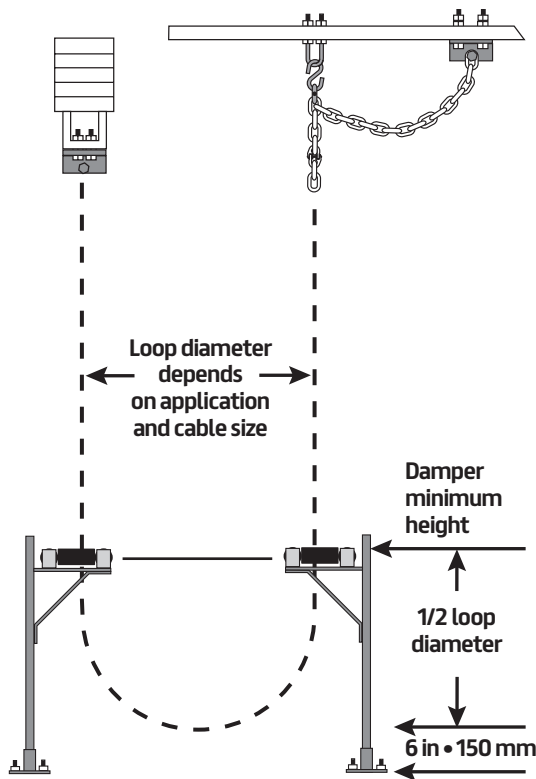
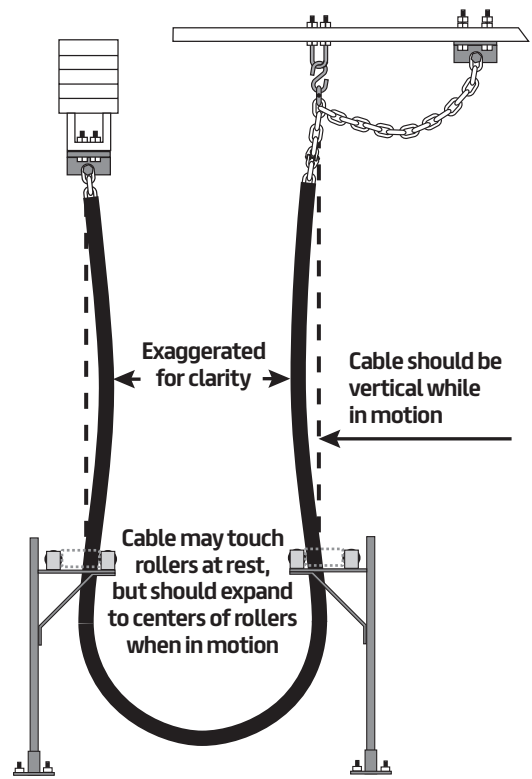

Figure 4



Draka EHC

A Brand of Prysmian Group

Draka EHC
2151 N. Church Street | Rocky Mount, NC 27804
+1-877-DRAKA EP (877-372-5237)
www.DrakaEHC.com | www.prysmiangroup.com